



# Faceeast

vandewielegroup.com



VAN DE WIELE GROUP  
**BOOTH H3 C202**  
MEMMINGER-IRO  
**BOOTH H3 B114**  
PROTECHNA  
**BOOTH H3 E182**



ITMA 2011

22-29 SEPTEMBER  
BARCELONA



# Inventors of the electronic Jacquard, always in the lead!

Reliable, efficient, profitable ... that's what we hear from our customers when we sound out their experience of Bonas Jacquards running in their plant. This is not a coincidence; we at Bonas Textile Machinery are dedicated to invent, develop and manufacture the best for our customers.

Your customer expects the best fabric quality from you so we commit to offer the best Jacquard to you.

You deserve the best technology! You deserve a Bonas Jacquard!



## Bonas helps you to design your future.

The designs you create demand shed geometry accuracy to become the perfect woven fabric. For this you can rely on Bonas Jacquards. The LJ and ZJ models are one family of products, sharing the same proven technology and benefitting from all attributes of our modern manufacturing facilities. The selection is 100% electronic, making 100% diagnostics possible - avoiding mis-selections.

Easy and almost infinite shed formation settings are possible.

### **Bonas adjustable split heck and split terry heck;**

Separation of the warp ends, front to back, odd or even, ground or pile, at crossing, easily done, without tilting the Jacquard head. Only possible on Bonas Jacquards!

Cam profiles for dwell shed control offer increased weft insertion time, without increasing the shed travel, resulting in up to 20% reduction of yarn stress. These attributes benefit weaving efficiency and fabric quality.

The well balanced drive mechanism and approved selection system of both the LJ and ZJ result in **low power consumption**, regardless of speed, temperature or voltage.

From flat to terry, from rapier to air-jet machine, choosing Bonas Jacquards is simply the most profitable option you can make.

The constantly growing success of the Bonas range and our expanding sales and service centers across the world are the result of our commitment to quality and to you, the weaver.

## Let's design our future together!



## Aros electronics AB

# The end of mechanical shedding is approaching

More and more, electronics are integrated into the weaving looms. Until today, the shedding is still done by conventional mechanical dobbies.

With the new AROS electronic shedding motion, this era can come to an end.

The iShed (intelligent shedding) gives you energy savings due to the optimised energy consumption through inertia recovery.

- Electronic pick finding is done independent from the loom
- Variable shed opening is fully flexible
- All different patterns can be woven
- Full electronic cam law transfer
- Variable crossing position for each held frame

The whole system is very compact, user friendly and requires a limited maintenance. This new iShed will give a lot of opportunities for the users and results in better efficiency, higher productivity and less power consumption.

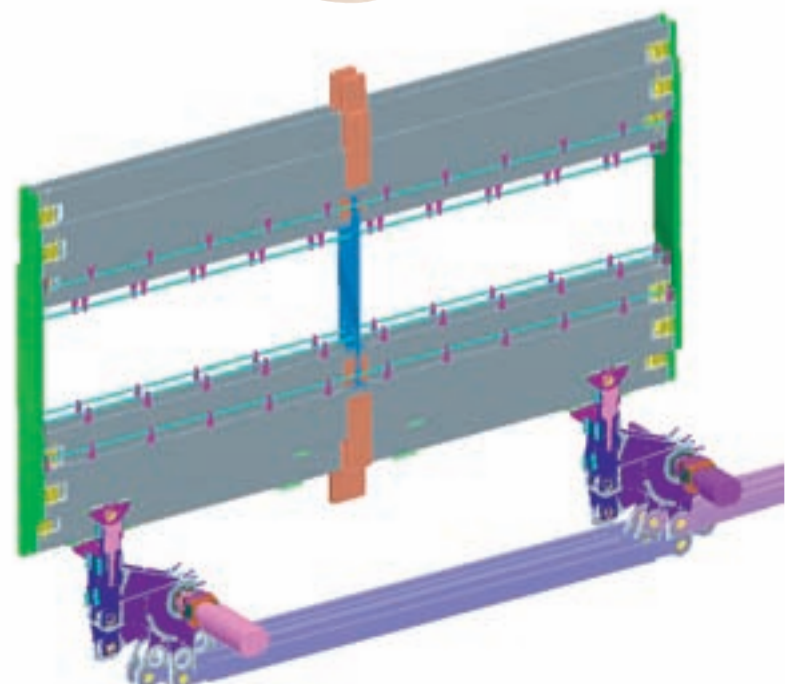
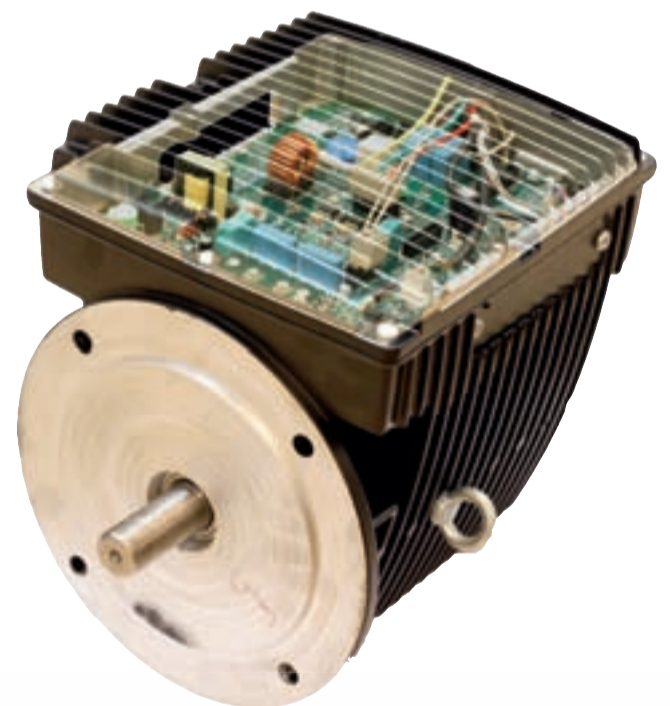



# Split adjustable heck

## Split adjustable heck and split adjustable terry heck

... two well appreciated features, available on both the LJ and ZJ models and only possible on Bonas Jacquards.

By separating the neighboring warp ends at crossing, a lot of problems, such as filament breakage leading to second choice fabrics, sticking warp ends or slack pile warp ends - in case of terry weaving -, both leading to troubled shed and weft stops, can be avoided. Needless to say these applications lead to a better weaving efficiency and better fabric quality thus saving you a lot of money.

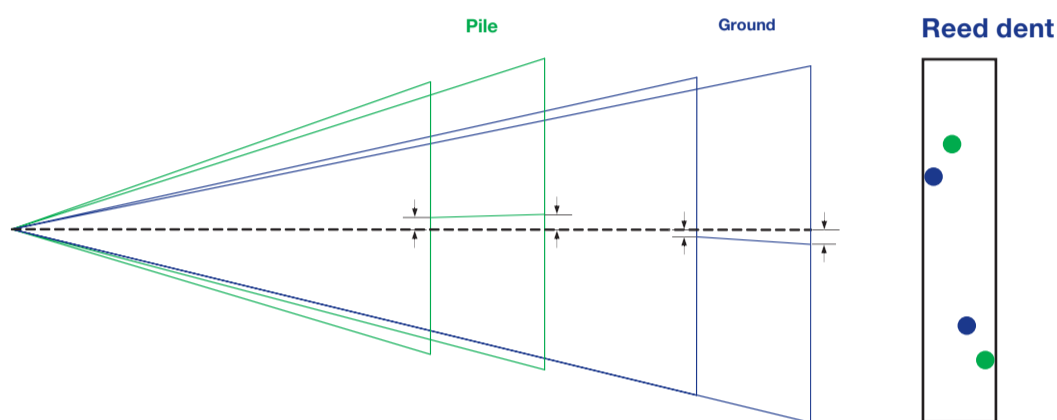

# Low power consumption, low running cost.

**ZJ** for rapier and airjet applications and ZJs for high speed applications, both with capacity 768 – 2688 hooks. Compact and robust at the same time.



## Maintenance friendly

Easy access – makes servicing simple and quick. Part changes, if ever required, are efficient and cost effective due to simple independent selector parts.

**Ergonomic! Maintenance Easy!**

## Low running cost

Jacquard power consumption, compared with an average weaving plant, is small. However we at Bonas are committed to make it even smaller. In ten years we reduced solenoid power consumption by 85%. With today's LJ & ZJ balanced, minimum friction and low torque mechanism, you can be sure power consumption remains as efficient and effective for the next ten!

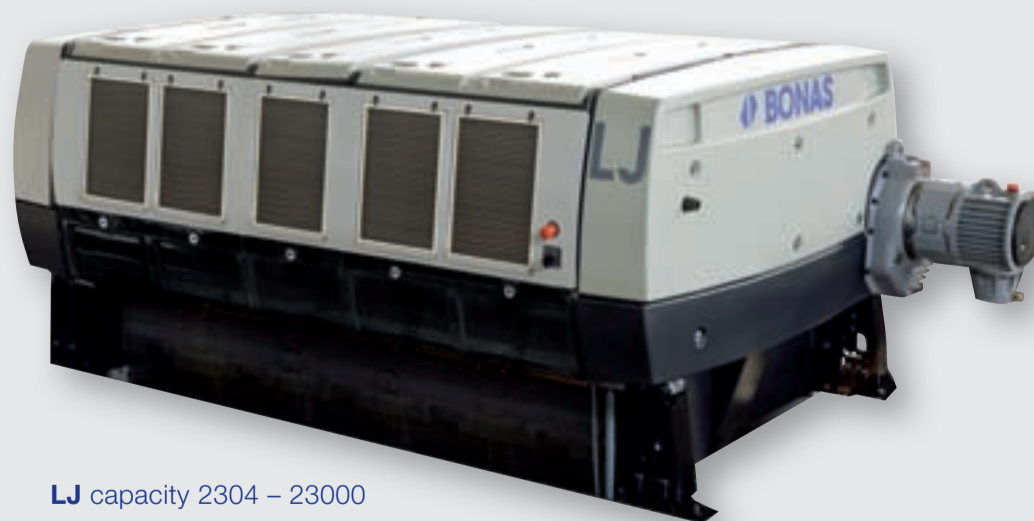

**LJ** capacity 2304 – 23000  
Enjoy the power of LJ with double cam boxes offering dwell for maximum flexibility.

# Maintenance friendly



## Innovation by Van de Wiele creates new challenges for the carpet and velvet industry

The **innovator** generation of carpet weaving machines gives a boost to the carpet industry. The unlimited possibilities in creation and design guarantee the future of the carpet weavers.

The heart of the new developments is the **Rug & Carpet Innovator** in two and three rapier execution, respectively **RCi02 and RCi03**.

The new RCi machine can be equipped with Smart Frames for the drive of the ground heddle frames and has a Smart Cutting Motion. The RCi has Smart Edges and is controlled by the Modular Loom Control. The Innovator generation is characterised by an increased productivity (especially in **5m width**) and a better stability.

The conventional heddle frame drive by cams is characterised by a fixed ground weave structure. With **Smart Frames** (SF), each ground heddle frame is driven by a separate servo-motor. The traditional 6 heddle frame is now enlarged to a

choice between 6 up to 12 heddle frames. Smart frames allow easy changing of different ground weave structures. The use of servomotors gives unlimited possibilities for timing differences, different dwells and asymmetric motions. This results in a clear carpet back and regular pile height. The machines run with a high weaving efficiency with less incorporated yarns. All these features are not possible with a conventional electronic dobby with simultaneous and symmetric shedding.

The new **Smart Cutting Motion** (SCM) with servo drive guarantees a perfect cutting. The cutting frequency as well as the sharpening of the knife are programmable.

The selvedge yarns of the **Smart Edges** (SE) are driven by small servomotors, placed under the cumberboard for good accessibility and adjustment in width.

The **Modular Loom Control** (MLC) increases the capacities of the machine and reduces at the same time the cabling. The energy bus system recuperates kinetic energy coming from the motors.

The Rug & Carpet Innovator RCi03, the **three rapier execution**, gives 50% more production in 2/3 V. Moreover, the machine is characterised by an increased weaving efficiency and a clear carpet back side.



*Weaving on a width of 5m eliminates small carpets and runners that are sold under cost price.*

### The carpet industry profits from weaving on a pile width of 5m.

A very important development of Van de Wiele is the engineering of carpet weaving machines of 5 meter width. Due to the strong and stable construction of our machines with amongst others 4 gearboxes to drive the reed, most of our machines are available in a width of 3 meter, 4 meter or 5 meter.

Weaving area rugs on a 5m machine gives **more saleable sizes of carpet**. On a 4m machine, numerous small carpets and runners are woven. These carpets are quite expensive and sold under cost price. On a 5m machine, you can better fit commercial sizes in width like 3m and 2m, 2 times 2.5m, 3 times 1.6m etcetera. But also for wall-to-wall carpet and artificial grass, the width of 5m or 15 feet gives many advantages.

Proof is given by the many references of 5m machines in Belgium, UK, Turkey, Uzbekistan, Syria, Iran and China.

### Machine made carpets have never been as close to handmade carpets as today.

The **Hand Look Carpet Pioneer HCPX2** weaves qualities from reed 300 pile dents/m up to reed 700 pile dents/m and from 6 up to 10 pile colour frames.

Compared to the first developments in Hand Look and Crystal Point, Van de Wiele has been able to develop a three rapier weave structure which has double production compared to the first generation and **50% more compared to similar qualities woven in a three shot weave structure on a double rapier weaving machine**.

The HCPX2 hand look weave structure is a **three rapier weave structure** in which the three rapiers are always inserting fillings. The back side of the carpet is just like the handknotted carpets. All pile tufts go to the backside, no ground yarns are visible and the pile fixation is perfect. The enhanced setting possibilities on the Jacquard machine and special ground warp shedding technology give a superior back side. As the HCPX2 is a three rapier weaving machine, the incorporated pile yarns are not moving, leading to a clear back side and a high weaving efficiency.

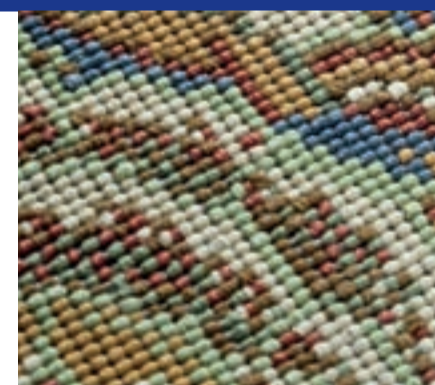

*Hand look quality in pile reed 700 d/m with no visible warp yarns on the back side, produced on HCPX2 with double production.*

The HCPX2 machine is running successfully in several countries like Iran, Belgium, Turkey and China in different widths, densities and number of colours. It is possible to go up to 10 colours in reed 700 d/m, 3m width or 8 colours, reed 600 d/m, 5 m width or 10 colours, reed 500 d/m, 5m width. Van de Wiele is developing a new hand look quality with 1000 pile dents/m in 8 colour frames. This quality will be the jewel in the crown.



## Long pile carpets, with cut pile and/or loop pile are increasing their market share

What originally started as a fashion in Europe and Turkey, has now become a standard worldwide: Shaggy carpets or carpets with long cut and/or loop pile. The latest Domotex has proven that Shaggy has found its position in the market.



*Shaggy loop carpet is woven on the USP93 with a patented weave structure and special fork lancets for up to 2x50mm cut pile and loop pile 20mm.*



The **Shaggy Rug Pioneer SRP92** is a two rapier weaving machine, developed for weaving carpets with high cut pile. In the suppershaggy execution, a **pile height of 2 x 70mm** is possible. Therefore, special patented spoon lancets are used. The Jacquard machine gives the possibility for different V and W weave structures, creating special relief effects and assuring a perfect pile fixation. Especially for this kind of carpets, the use of different types of yarns like polypropylene, wool, acrylic, polyester, etc prove to be very successful.



The same machine can produce **artificial grass** in different qualities for sports and landscaping in a width **up to 5m or 15 feet pile width**.

The **Universal Shaggy-loop Pioneer USP93** is a three rapier machine for weaving carpet with long cut pile and loop pile. When combing cut and loop pile, the maximum pile height is 2 x 50mm. When only making cut pile, 2 x 70mm is possible like on the Suppershaggy SRP92. Also for this kind of carpets, it is important to be creative with different types of yarns such as wool, polypropylene, polyester and acrylic and combining different types of yarns and thickness.

When replacing the dummy yarn on the middle rapier by a thick filling that stays in the carpet, **shaggy carpets with cut pile and sisal look effects** can be woven. Additional colour effects are created by a filling selector.

Other models of the Van de Wiele machine range are the **Universal Cut and Loop Pioneer UCP93** for weaving carpets with cut pile, soft short and long loops and flat weave effects, the **Loop Pile Carpet Innovator LCI01** for carpets with soft loops and the **Sisal Look Pioneer SLP93** for weaving carpets with relief effects, used for indoor as well as outdoor.

The best machine for weaving light weight carpets and tapestry carpets, is the **Tapestry Rug Pioneer TRP92**. This machine, available in a width up to 2.5m, is producing carpets with design in cut pile and Jacquard ground effects in combination with a weft selector for 2x6 wefts.

## Smart weavers use smart creels.

The smart creel is the ultimate system to **save raw material**, to **reduce the cost** and to **reduce machine down-time**. The smart creel calculates the required amount of pile yarn necessary in each position of the creel for a certain order. This amount is filled into the tubes of the smart creel by a fully automated robot, while the machine is running. As the robot is managing the creel, less creelers are required and the saving on raw material is considerable. As the next order is being prepared while the machine is running, the downtime for creel changes is significantly reduced, increasing the overall efficiency of the mill.

The Smart Creel has proven to be successful for Axminster weaving, but is now also available for wilton weaving and velvet.

*Combination of sisal look with filling selector and shaggy carpet, woven on the Universal Shaggy-loop Pioneer USP93.*



*Woven artificial grass for landscape and sports on the Shaggy Rug Pioneer SRP92.*

## Axminster weaving machine MAX91

The **MAX91 Axminster** weaving machine weaves one single carpet according to a completely different technique. Grippers take only the pile yarn that is visible and no incorporated pile yarns are used. This results in high quality carpets with **up to 16 pile colour frames** in pitch 7 DPI. Typical applications of these, mainly woollen/nylon, carpets are wall-to-wall carpets for hotels, cruises, offices, casinos,... However there is an increasing demand for area rugs woven according to the Axminster technique as well, especially with the hand-look weave structure.

*A combination of fashionable plain and Italian velvet woven on the Velvet Tronic VTR.*



*Head of the robot of the Smart Creel that fills the tubes with the length of pile yarn that is needed according to the woven carpets.*



*The MAX91 can weave a broad range of carpet qualities in pitch 7 DPI with up to 16 colour frames without incorporated pile yarns.*

## The Velvet Tronic VTR for producing velvets and technical fabrics

The **Velvet Tronic VTR** is manufactured in a plain/dobby execution (VTR23) and a Jacquard execution (VTR33). The applications of velvet are numerous: upholstery, automotive, bus and train, curtain, chiffon dress, artificial fur,...

For the interior fabrics, there is a fashion towards the **Italian Velvet** with pile design combined with Jacquard ground effects. Van de Wiele is giving a new life to this Italian velvet by creating a new quality with **3 pile colours** in center draw and **2x4 backing yarns** per reed dent. The design possibilities become unlimited, especially when combined with a filling selector. The **LJVi3 jacquard** is equipped with 11520 solenoids. The **Velvet Tronic VTR42** is a special execution for **technical fabrics** such as distance fabrics, paintbrushes,...

*Velvet Tronic VTR33 for Italian velvet equipped with a LJVi3 jacquard of 11520 solenoids for 3 pile colours in center draw and 2x4 backing yarns per reed dent.*





**ROJ**

Exceed your expectations

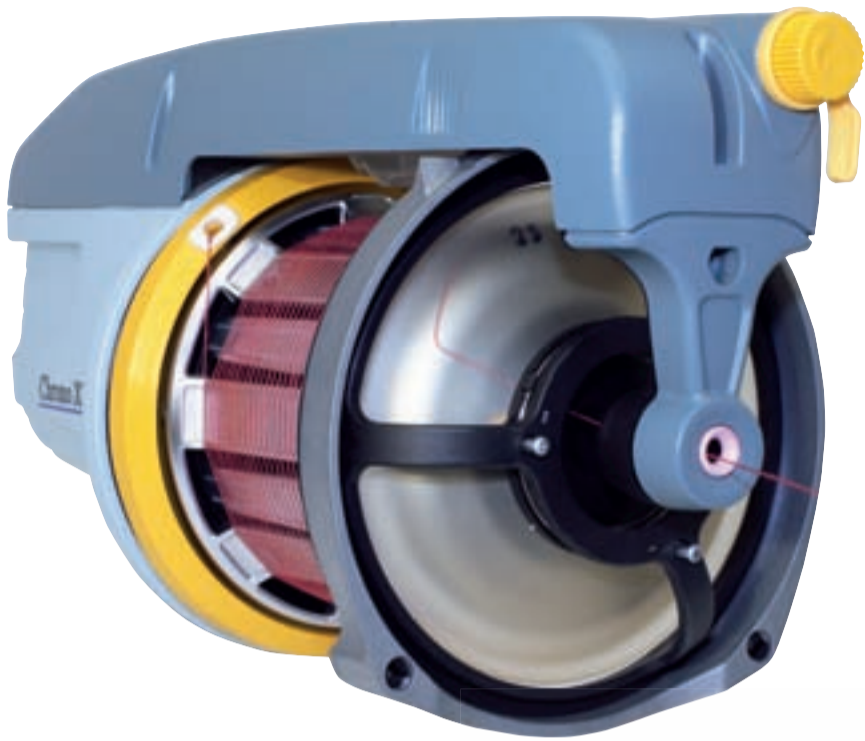

### Chrono X3

The new Chrono X3 is our latest, most innovative and versatile product. Incorporating new developments such as the "M-Flex" and improved accessibility for connecting powered accessories. Chrono X3 also comes with many well established and proven features.

- M-flex - new compensating tensioner and balloon control
- Specially designed spool-body for excellent yarn handling
- Connection to our light-weight switch-mode power-supply and interface control box.
- Improved accessibility for connecting powered accessories
- Energy efficient permanent magnet motor.



### ROJ Super Elf X3

The Super Elf X3 is based on a platform proven on 25.000 feeders delivered in 2010. The culmination of years of experience in air-jet and water-jet weft feeders, ensuring the highest performance, versatility and reliability.

- New and innovative "barrier principle" optical sensor system for excellent sensing of any yarn at all speeds.
- Reliable reading of very fine yarns, as fine as 7 den.
- Stable reading of yarn storage in dirty and dusty environments.
- Compact sensor/stopper-magnet housing to reduce friction with heavy yarns.

### Accessories

To optimize feeder performance we have a comprehensive range of accessories. For more details please visit our website to see the full range of accessories available.

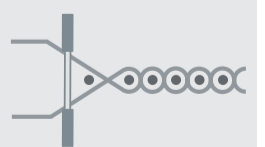
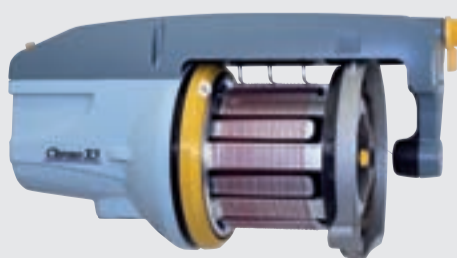

When it comes to leading-edge processing technology for yarn feeding, control systems and lubrication technology for knitting machines, Memminger-Iro is the market leader



With 50 years of experience in this sector, we are now perceived as a trendsetter for the standards which others are glad to follow. A multitude of patents and future-oriented developments have earned us a worldwide reputation.

As an internationally operating group, MEMMINGER-IRO GMBH has over 400 employees worldwide. The company headquarters is located in Dornstetten/south-west Germany. With five subsidiaries and sister companies as well as over 80 representatives, MEMMINGER-IRO GMBH distributes its products in more than 100 countries.

### Memminger Positive feeder MPF P

MPF P is the latest generation of the world renowned MPF Memminger Positive Feeders. The totally redesigned unit underpins our units tradition for positive, unhindered yarn feed to ensure consistent quality and faultless production. Particular importance has been attached to easy threading, increased productivity and multiple application. A reduced number of yarn guiding elements allows quick and easy threading of the unit. A big integrated stop lamp with latest LED technology can be easily recognised by the operator. This increases machine productivity by reducing down time. The spool body is exchangeable; three versions are available. To avoid filamentation the outlet can be adjusted into two positions.



### Opto-electronic thread control systems for the textile industry.

Surveillance devices for

#### circular knitting machines

- digital needle sensor

#### warp knitting machines

- needle surveillance
- fabric surveillance
- weft thread surveillance
- selvage thread control

#### weaving machines

#### warping machines



### advanced knitting technology

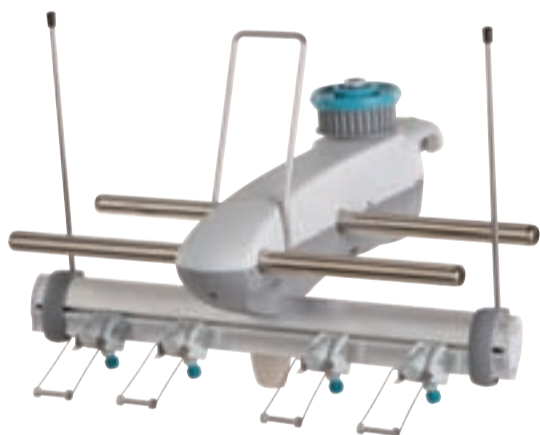

### Memminger Elastane Roller MER 3

MER 3 is designed to process bare elastane on large diameter circular knitting machines. Due to an optimized transmission the unit can be applied to both single and double jersey machines. The unit can be connected to each available 12/24 V AC/DC stop circuit. The stop motion system is totally redesigned which allows to process the finest yarns with the lowest yarn tension. The centralised stop lamp with LED technology can be recognised from the operator very quickly which helps to reduce machine down time. The inexpensive cover protects the elastane bobbins from fluff, this allows a dramatic increase in productivity.



### Knitting machine controller NAVIGATOR

The NAVIGATOR system incorporates all electronic and electric parts which are needed to run a large diameter knitting machine. The system contains control unit with control terminal, distributor boxes, static frequency changers with transformers, all control keys, all safety switches inclusive main switches and the machine lighting. MEMMINGER-IRO delivers all necessary parts only as one supplier. The NAVIGATOR system is prepared to connect all MEMMINGER-IRO products directly. Connections for the controllers (SIEMENS, WAC) of the strippers and needle selections on stripper and jacquard machines is provided. The surface of the software and the components are customized.



### Storage feeder MSF 2

MSF 2 has been designed for the feeding of yarn at a constant and variable feed rate to knitting and hosiery machines. It has a stationary winding body and yarn winding transport system to ensure a 1,0 mm yarn separation. The MSF 2 optimises production rates and fabric quality. This feeder will handle all yarn types.

A yarn winding transport system within the stationary winding body ensures the continuous movement and separation of the yarn windings over the winding body, to provide a continuously wound perfect yarn store. This ensures that the feeder can process even the most difficult yarns. The newly developed, patented magnetic tensioner ensures a constant yarn tension at the outlet, with stepless tension adjustment. No additional yarn tension regulation is necessary. The unit is driven by a powerful brushless DC motor with microprocessor control. Sensor on the winding body monitor and calculate the average yarn usage rate and adjust the motor speed to the yarn consumption accordingly.

◀ **VAN DE WIELE**  
CARPET AND VELVET WEAVING MACHINES



◀ **BONAS**  
ELECTRONIC JACQUARDS



◀ **TITAN**  
FINISHING MACHINERY



**iro**  
FEEDERS



# innovation through creativity

vandewielegroup.com

USA  
UK  
BELGIUM  
FRANCE  
GERMANY  
ITALY  
SWEDEN  
RUSSIA  
TURKEY

INDIA  
SHENYANG  
JINAN  
SHENGZE  
SHAOXING  
GUANGZHOU  
HONG KONG  
SOUTH-KOREA  
TAICANG  
WUXI  
TAIWAN

**ROJ**  
FEEDERS/CONTROLLERS

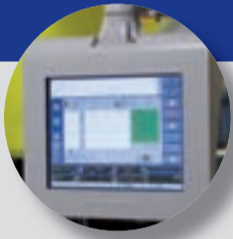

**MEMMINGER-IRO**  
KNITTING TECHNOLOGY



**PROTECHNA**  
QUALITY ASSURANCE FOR TEXTILES



**Aros electronics AB**  
DRIVES

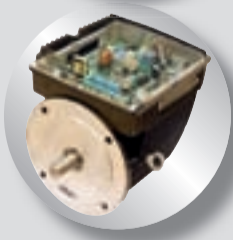

◀ **FERROMATRIX**  
AUTOMATED HIGH PRECISION  
IRON FOUNDRY



◀ **VIGAN**  
BULK HANDLING



We share our knowledge and expertise in the broad area of textile technology.

Due to research and development, in a close relationship with our customers, the Van de Wiele group offers a comprehensive range of equipment designed to meet the ever growing demands of the textile industry such as the knitting industry, pile and flat weaving, weaving and knitting accessories, finishing equipment, frame weaving, control systems, ...

◀ **VAN DE WIELE**  
group of companies

Michel Vandewielestraat 7  
B-8510 Kortrijk (Marke) - Belgium  
www.vandewielegroup.com